

VST1/VST1B/VST1M/VST1MB - DIAZ STEPLIGHT

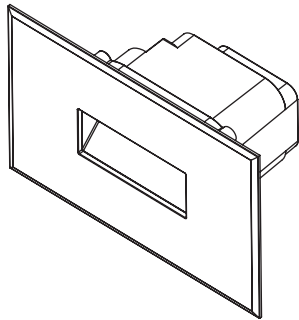
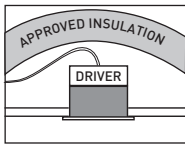

SAFETY

This product should be installed by a suitably qualified person in accordance with Australian and New Zealand wiring rules.

CLEARANCES FROM COMBUSTIBLE MATERIAL

This luminaire has been independently tested and is rated for IC-4 and IC-F installation.

This product is suitable for use with building insulation that can safely be continually exposed to temperatures up to 90 °C and must withstand a 30s needle flame test carried out in accordance with AS/NZS 60695.11.5, with the flame applied to all surfaces of the sample.

Loose fill insulation as defined in NZS 4246 is not permitted to abut or cover luminaire.

RISK OF FIRE

Required clearance from structural members and building elements
SCB=0mm MIC=0mm HCIB=0mm SCI=0mm

WARRANTY

The Diaz Steplight is guaranteed for a period of three years from the date of purchase against defects in workmanship and materials. Defects will be rectified by replacement of the product.

This warranty becomes null and void if in our opinion the product has been misused, incorrectly installed, tampered with, or subject to power surges. The warranty does not include any labour or other associated expenses that may be involved in removal or installation of the product.

To obtain a replacement under this guarantee, return the goods (prepaid) to the place of purchase (proof of purchase must be supplied).

SPECIFICATIONS

Rated Operational Voltage	230-240V AC 50Hz
Colour Temperature	3000K
IP Rating (Front Body)	IP44
IK Rating	IK06
Fascia Colour	White, Black
Material	PC
Dimmers	Compatible with Vynco, Clipsal, HPM and PDL trailing edge dimmers
Suitable for indoor areas only. For further specifications, refer to our website at vynco.co.nz .	

DIMENSIONS

Height	108mm
Width	56mm
Depth	52.5mm

VYNCO INDUSTRIES (NZ) LIMITED

CHRISTCHURCH

388 Tuam Street, Phillipstown, Christchurch, 8011
PO Box 9022, Tower Junction, Christchurch 8149
New Zealand
P +64 3 379 9283
E sales@vynco.co.nz

VYNCO.CO.NZ

AUCKLAND

9 Levene Place, Mount Wellington
PO Box 12 249, Penrose, Auckland 1061
New Zealand
P +64 9 525 6051

VST1/VST1B/VST1M/VST1MB - DIAZ STEPLIGHT

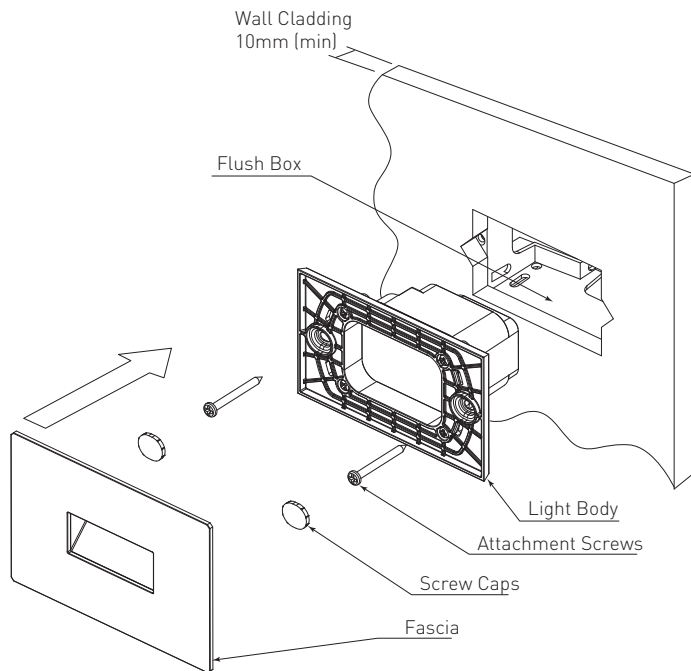

WIRING

L = Live or Phase – Brown or Red
E = Earth - Green or Green/Yellow
N = Neutral- Blue or Black

WIRING INSTRUCTIONS

1. Always disconnect the power to the fitting before removing any covers.
2. This light must be installed into a flush box, mounted behind wall cladding (minimum 10mm thick) with the use of two screws.
3. Using a suitable tool cut a hole around the internal perimeter of the flush box, including notches to access the threaded screw bosses.
4. After ensuring circuit is isolated, terminate wiring in an approved manner.
5. Insert the light into the opening and secure in place with the two provided screws.
6. Screw heads must be covered with the supplied screw caps.
7. Energise and test.
8. Clip the fascia plate onto the light, the fascia can be levelled using 2 degrees of rotation provided by the fascia.

NOTE: The light source of this luminaire is not replaceable; when the light source reaches its end of life the whole luminaire shall be replaced. This product contains NO user serviceable parts.