

VBG001 / VBG005 - BOND MAGNETIC GRILLE BASE

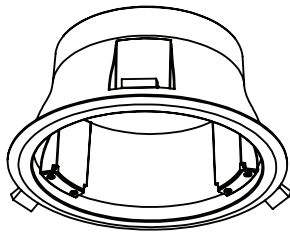

SPECIFICATIONS

| | |
|--------------|-------|
| Duct Size | 150mm |
| Cut Out Size | 185mm |

INSTALLATION DIAGRAM

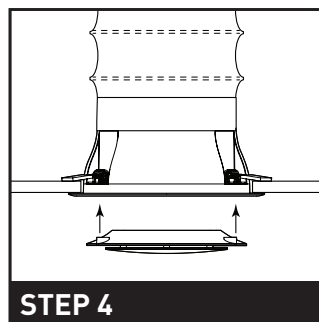
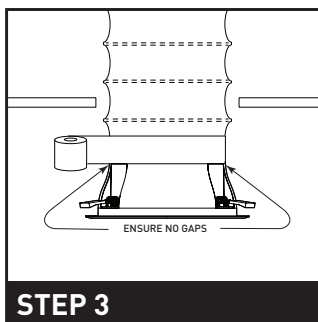
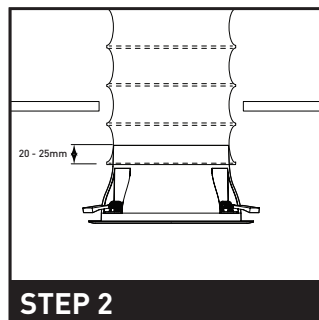
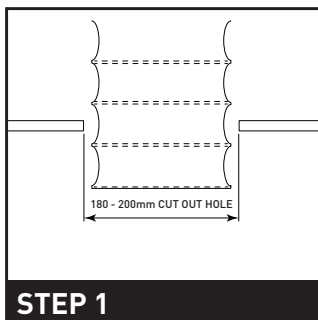

WARRANTY

This product is covered by the standard 3 Year Vynco Warranty - proof of purchase is required. Please contact Vynco for details of returns procedure.

NOTE: This product contains NO user serviceable parts.

INSTALLATION PROCEDURE

STEP 1

Cut a 180mm to 200mm diameter hole in the ceiling and pull the 150mm duct through.

STEP 2

Slide the duct over the grille base.

Caution: Only slide the duct down 20mm to 25mm and leave plenty of room for the tape to seal.

STEP 3

Tape the duct to the grille base ensuring there are no gaps between the duct and base.

Caution: Check there are no gaps between the tape and base to prevent moisture from escaping from the duct into the ceiling space.

STEP 4

Fit the grille base and duct into the ceiling and fit the supplied grille.

VYNCO INDUSTRIES (NZ) LIMITED

CHRISTCHURCH

388 Tuam Street, Phillipstown, Christchurch, 8011
 PO Box 9022, Tower Junction, Christchurch 8149
 New Zealand
 P +64 3 379 9283 F +64 3 379 6838
 E sales@vynco.co.nz

VYNCO.CO.NZ

AUCKLAND

9 Levene Place, Mount Wellington
 PO Box 12 249, Penrose, Auckland 1061
 New Zealand
 P +64 9 525 6051 F +64 9 525 5799