

# VYNCO

## PIR SENSOR MODULE

220-240Va.c. 50Hz, Max. 800W



- Max detection range 5 meters
- 120° Horizontal, 70° Vertical detection angle
- 5 seconds – 30 minutes
- 10 – 2000 Lux range

# 88PIRM



- Ideal for use in hallways, stairwells, toilets and other low use areas.
- 88PIRM can be fitted to a Switch plate in two directions for a narrow or wide sensing angle.
- LED indicator on front to show when movement is detected.
- Fits all Vynco – Logix, Fusion and Home – Switch Plates.
- Suitable for controlling all types of loads – Incandescent, LED, Fluorescent and small fans.
- Maximum Range – 5 metres.
- Time control from 5 seconds to 30 minutes.
- Lux control from 10 to 2000 Lux.



## DETECTION

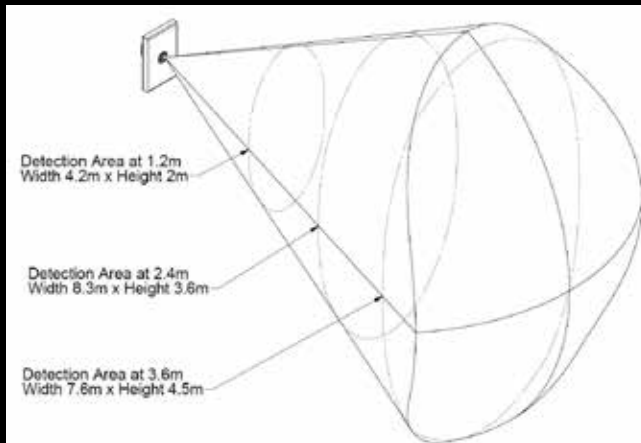

Rotate the mech in the plate to change the detection range.

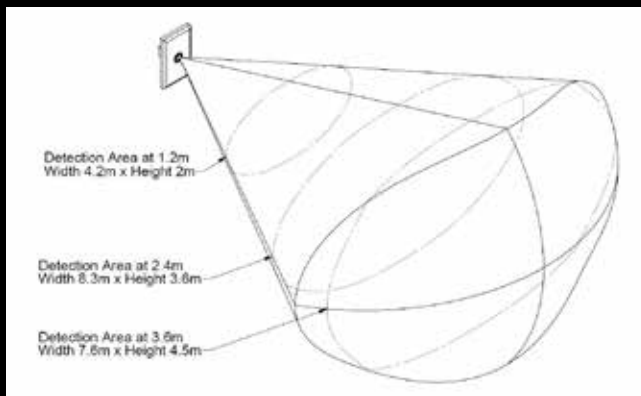

## VYNCO INDUSTRIES (NZ) LIMITED

### Christchurch Office

388 Tuam Street, Phillipstown, Christchurch 8011  
PO Box 9022, Tower Junction, Christchurch 8149  
New Zealand

**P** +64 3 379 9283 **F** +64 3 379 6838

**E** [chchsales@vynco.co.nz](mailto:chchsales@vynco.co.nz)

### Northern Region/Auckland

58 Walls Road, Penrose, Auckland 1061  
PO Box 12 249, Penrose, Auckland 1642  
New Zealand

**P** +64 9 525 6051 **F** +64 9 525 5799

**E** [vyncoauck@vynco.co.nz](mailto:vyncoauck@vynco.co.nz)

[www.vynco.co.nz](http://www.vynco.co.nz)